



## INSTRUCTIONS FOR USE

# Magrini Baby Change Unit - Model MT80

### **IMPORTANT: RETAIN FOR FUTURE REFERENCE. READ CAREFULLY.**

This changing unit must be fixed to a counter top for safe use of the product using the fixings supplied.

This unit does not require a changing pad and therefore, no pad is supplied with this unit.

To assure proper installation, we suggest that a qualified person install this unit. Magrini Ltd., will not be responsible if the changing station is not installed correctly.

All recommended fixings are supplied. Replacements are available free of charge from Magrini - do not use less substantial fittings.

### **Changing Unit Fixing Parts (supplied):**

10 No. Pozidrive Screws  
10 Gauge x 20mm



2 No. Allen Screws  
M5 x30



### **Tools required:**

- No.2 Pozidrive Screwdriver
- Allen Key Bit (supplied)
- Drill
- Silicone Sealant

### **Cleaning Instructions**

The nappy changing unit may be washed and wiped with a damp soft cloth or sponge. Use of mild detergent and warm water will remove the majority of dust and stains. For more obstinate stains a domestic cream cleaner can be used. Do not use any abrasive cloths, caustic or solvent cleaners as these may damage the unit.

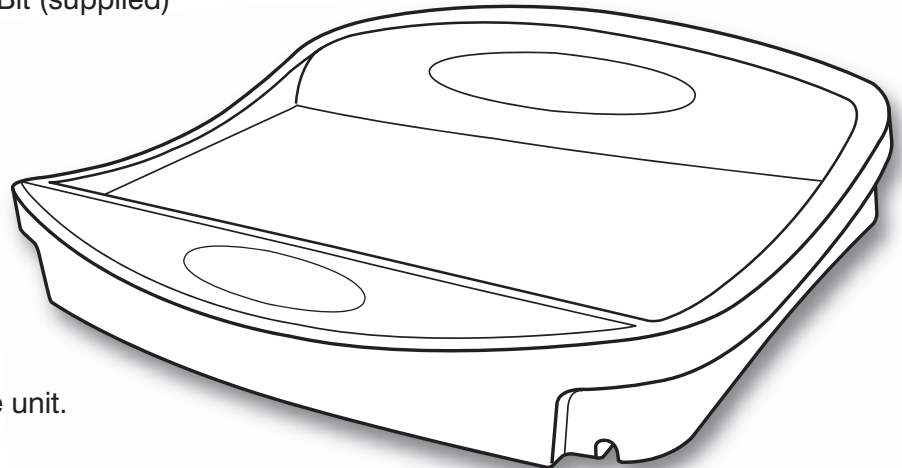

### **Maintenance Instructions**

Check that the unit is securely fixed to the counter.

Ensure warning label is in place on the inside of the unit and general cleanliness is within given guidelines.

Any replacement parts must be obtained from Magrini only.

**Note: All assembly fittings shall always be correctly tightened and checked regularly. Screws shall not be loose because a child can squeeze parts of the body, or clothing (e.g. strings, necklaces, ribbons for babies, dummies, etc.) could get caught. There would be danger of strangulation. Units should be fitted no less than 100mm from the corner of the room to enable access for cleaning. Be aware of the risk of open fire and other sources of strong heat, such as electric bar fires, gas fires etc. in the near vicinity of the unit.**

### **WARNING: DO NOT LEAVE THE CHILD UNATTENDED.**

Weight/age of the child for which the product is intended: 12 months, up to 11kg.

Do not use the changing unit when any part is broken, torn or missing.



Magrini Limited, Unit 5 Maybrook Industrial Estate, Brownhills, Walsall WS8 7DG  
t: 01543 375311 • e: sales@magrini.co.uk • w: www.magrini.co.uk



## INSTRUCTIONS FOR USE

# Magrini Baby Change Unit - Model MT80

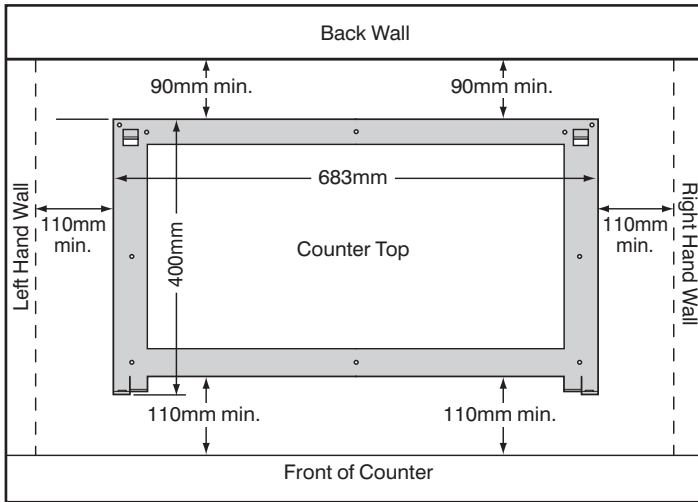

Position frame on counter top.  
Allow the minimum dimensions as shown.

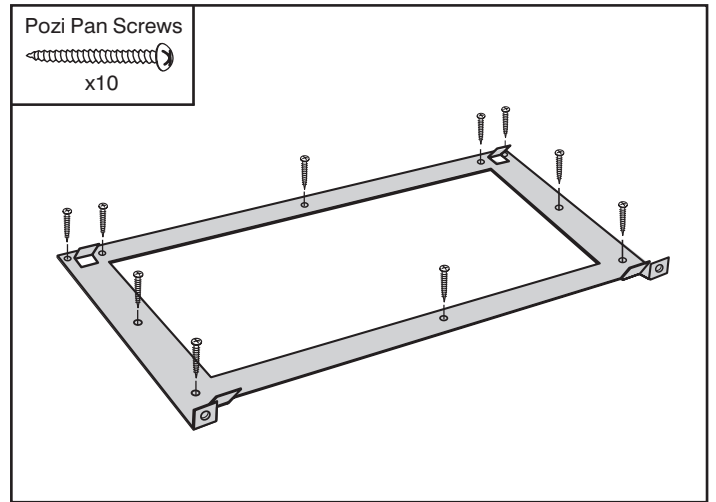

Secure frame using the 10 gauge x 20mm screws provided.

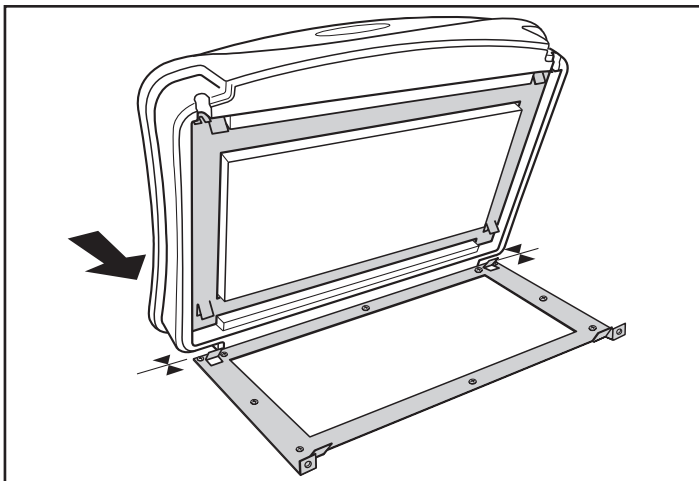

Position unit centrally at back of the frame.

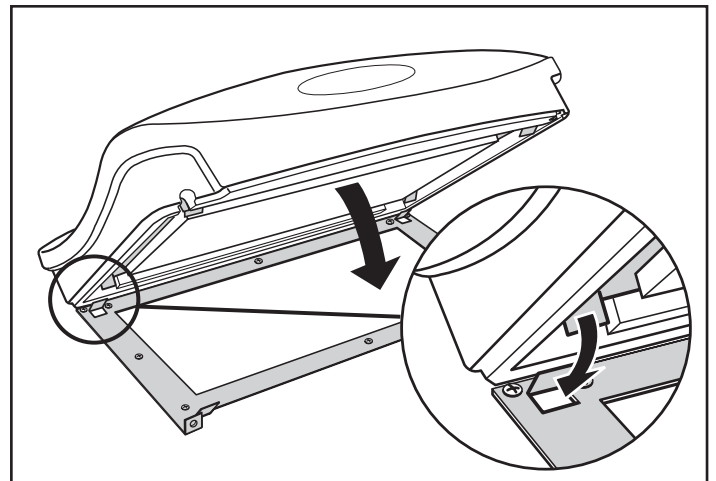

Lower unit over frame. Take care to align tabs as shown.

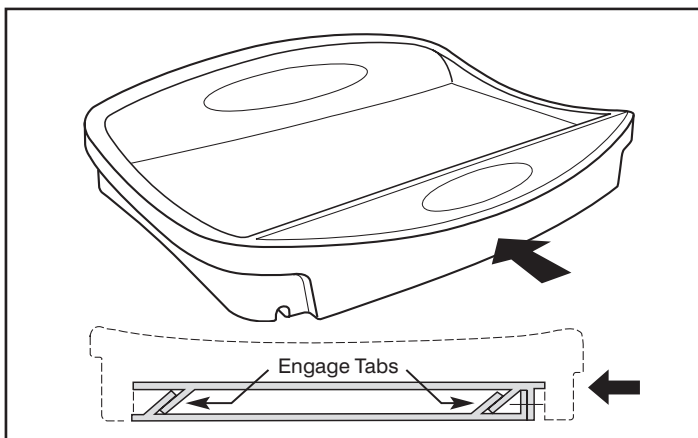

Push unit back until the tabs engage fully.

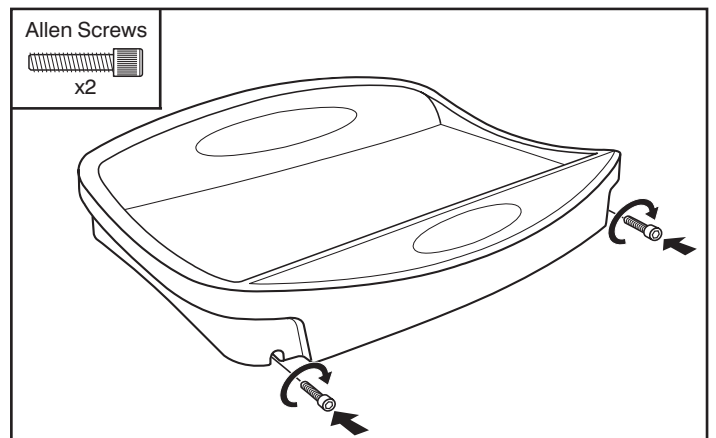

Secure with the two M5 x 30mm screws provided.  
We recommend that the unit is sealed around the bottom edge with silicone sealant.



Magrini Limited, Unit 5 Maybrook Industrial Estate, Brownhills, Walsall WS8 7DG  
t: 01543 375311 • e: sales@magrini.co.uk • w: www.magrini.co.uk